



Introduction

The easy Radio Integrated Controller (eRIC) radio transceiver module is based on the Texas Instruments CC430F5137 System-on-Chip device to provide an intelligent radio sub-system that combines a high performance RF transceiver, RF band pass filters (BPF), an MSP430 microcontroller, 32Kb flash memory, non-volatile flash storage, temperature sensor, and a low drop voltage regulator. The device operates on the International licence exempt Industrial, Scientific and Medical (ISM) radio bands.

eRIC thus extends the proven easyRadio product line by offering a low cost RF transceiver intended for high volume applications. The compact form factor, surface mount packaging and external antenna connector simplify product design and manufacture and provide for flexible placement of the module within an end product.

Features	Benefits
<ul style="list-style-type: none"> • Default 'easyRadio' Protocol Embedded • ISM Frequency Bands • Radio Compliance 	<ul style="list-style-type: none"> Simple serial data in/data out user interface and configuration 433 & 868MHz (UK & Europe) & 915MHz (USA) Meets ETSI RED (Europe) & FCC Certified (USA) IC (Canada) requirements
<ul style="list-style-type: none"> • Small 15x20x2.2mm Surface Mount Device (SMD) • Low power operation modes • Configurable & programmable User I/O • AES 128 bit data encryption • Built in Temperature Sensor 	<ul style="list-style-type: none"> Simplifies product design and manufacture Battery powered applications Minimises external hardware requirements for custom applications Secure communications Environment monitor

Applications

eRIC4 & 9 are suitable for any device requiring upto 500 metre range and low power operation. Popular in battery powered applications sensors and actuators high noise harsh environments, eRIC4 & 9 transceiver provides a robust and reliable wireless engine for OEM's to take advantage of.

RAIL | SECURITY | FINANCE | ASSET TRACKING | INDUSTRIAL CONTROL | SENSORS | REMOTE MONITORING

AGRICULTURAL | DATA LOGGING | SMART HOME | INTERNET OF THINGS | MACHINE TO MACHINE |

INDUSTRIAL SENSING | ENERGY MONITORING | HVAC CONTROL AND MONITORING | FACILITIES MANAGEMENT

Contents

1. easyRadio Operating System (eROS).....	3
2 Pin/Pad Description.....	3
3 Absolute Maximum Ratings.....	5
4 Mechanical.....	7
4.1 PCB Layout Notes.....	7
4.2 Production - soldering & reflow.....	8
4.3 Soldering Paste & Stencil Thickness.....	8
4.4 Conformal coating.....	8
5. Interface to Microcontroller.....	9
6. Serial Data Timing.....	10
7. easyRadio eRIC Configuration Command Set.....	11
8. Transmission restrictions.....	16
8.1 eRIC transmission guide.....	17
9. Product Order Codes.....	17
9.1 Firmware.....	17
9.2 Programming Modules in Situ.....	17
9.3 MTBF.....	17
10. Regulatory Approvals.....	17
11. Document History.....	18

I. easyRadio Operating System (eROS)

eRIC's microcontroller is pre-loaded with eROS which handles all the complex radio functions thus eliminating the need for the user to program multiple control registers and understand their interaction.

Each eRIC is pre-programmed with a subset of the familiar easyRadio command and communication structure that allows key operating parameters such as operating frequency, RF power output and host communication settings to be (optionally) pre-configured using the 'easyRadio Companion' software or to be dynamically changed using simple serial commands sent from the customers application host microcontroller. This allows multiple eRIC devices to communicate free from interference with each other and other local RF devices.

Data is simply sent to and received from the customers host microcontroller using 3.3V logic level serial data (inverted) with packet sizes up to 250 bytes.

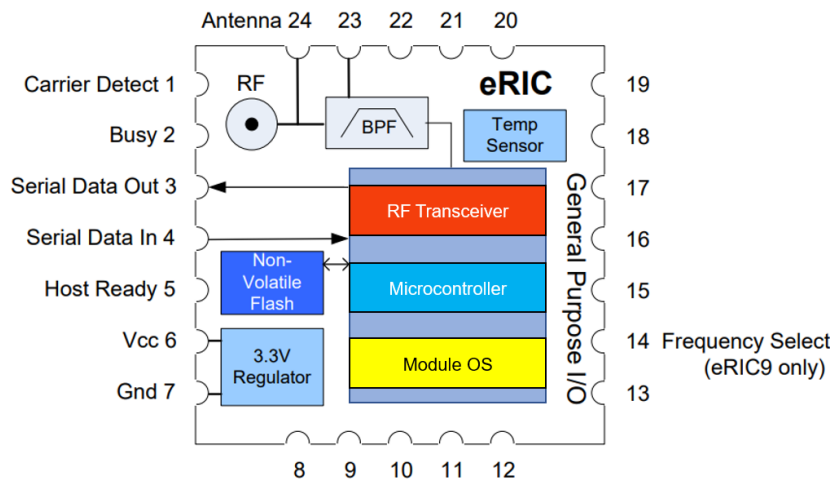

Figure 1 eRIC Transceiver Block Diagram

2 Pin/Pad Description

Pad No	Name	Description	Notes
1	CD	Carrier Detect Digital output	Indicates presence of any RF carrier within the receiver bandwidth Idle – Low, Carrier Present – High Optional A-D Input
2	Busy	Clear to Send (CTS) function Digital output	Indicates that transceiver is ready to receive serial data from the Host. Low – Transceiver Ready, High – Transceiver not Ready Optional A-D Input
2 (Option)	RF Rx Data	Demodulated receiver data Digital output	Only active when RAW Data mode is enabled
3	SDO	Rx Serial Data Out (Default)	Digital output - Connect to Host serial input
4	SDI	Tx Serial Data In (Default)	Digital input - Connect to Host serial output
5	Host Ready	Request to Send (RTS) function Digital input	Used to indicate that Host is ready to receive serial data from the Transceiver Low – Host Ready, High – Host Not Ready Weak (35k) pull down enabled. Optional A-D Input
6	Vcc	Operating Supply Voltage	+2.4V to +6V. Supply should be 'clean', noise and ripple free
7	Gnd	Power Ground	0V Ground
8	JTAG	JTAG pins	Reserved Use – Do not connect
8	Bootloader Recovery	Using a specific sequence on Pin8, module can be recovered and set into bootloader mode using LPRS BSL (Boot Strap Loader).	Only available on modules manufactured in 2015 or on old modules which were upgraded using easyRadio Companion software 4.0.4 onwards. Connect Pin11 and Pin12 together first. On holding module in reset or holding Pin9 (Reset) low, toggle Pin8 4 times. After 4 toggles, hold Pin8 high and release reset or unground Pin9. This will set the module in recovery bootloader mode which is indicated by Pin17 going high. From this state module can be re-flashed or repaired with eROS and eRIC.

9	Reset	Reset & JTAG use	Restricted Use – Internal pull-up. Connect to Gnd for Reset
10	GPIO	General purpose digital I/O	
11, 12	GPIO	Bootloader & General purpose digital I/O	When both pins connected invokes the bootloader function on reset. Do not connect for normal operation.
11	Temporary Recovery	Resets module temporarily to UART 19200 and CPU 4500000Hz.	Only available in V1.5 onwards. If the module fails to respond, it can be temporarily recovered by holding Pin 11 high on reset. This will temporarily reset the module to UART 19200 and CPU 4500000Hz. At this point sending ER_CMD#R0 will reset the module to default settings and fix it.
13	GPIO	General purpose digital I/O	
14	GPIO	General purpose digital I/O	eRIC4 only – See variant below:
	Input	Frequency Select EU/US	eRIC9 only. Pin High - 869.75 MHz (Default), Pin Low - 915.00MHz Internal pull-up enabled
15	GPIO	General purpose digital I/O	
16	Output	easyRadio app running OK	Goes High 1mS every 1 second
17-21	GPIO	General purpose digital I/O	Mappable secondary function
22	GPIO	General purpose digital I/O	Optional A-D Input. Mappable secondary function
22	Interrupt (Low to High)		Exit Low power modes
23	RF Gnd	RF Ground – 0V	Connect to antenna ground and local ground plane. Internally connected to Power Ground 0V
24	RF	50R RF Input/Output	Connect to suitable antenna via 50R PCB trace or use the alternative UFL connector. See Approved Antennas P.5

Notes

GPIO Pins/pads are configured (by default) on power up or Reset as Inputs with internal weak pull downs. Therefore, exercise caution when connecting to any external circuitry.

Pins/pad 1-7 are physically (pin/pad sequence) and electrically compatible with easyRadio eRA400/900 Transceivers. Interrupt function available on Pins/pad 1, 2, 3, 4, 5, 22

If you would like to map functions like UART, SPI, I2C, TimerA, Compare/Capture I/O, GD0 please contact the office for further information

3 Absolute Maximum Ratings

Operating Temperature Range	-40° C to +85° C
Storage Temperature Range	-40° C to +85° C
Supply Voltage - Vcc	-0.3 to +6.0 Volts
All Other Pins/Pads w.r.t 0V Gnd	-0.3 to +3.3 Volts
Antenna	50V p-p @ < 10MHz See Note below

Performance Data: Supply +3.6 Volt ± 5%, Temperature 20° C

DC Parameters	Pin	Min	Typical	Max	Units	Notes
Supply Voltage (Vcc)	6	2.4	3.6	6.0	Volts	
Internal Regulator (Vreg)		2.95	3.3	3.65	Volts	
Transmit supply current	6		32	33	mA	+10dBm RF power output
Receive supply current	6		15		mA	Continuous mode @ 250kbps
Sleep Mode current	6		1.8		uA	TBA
Initial Power Up Time			5	50	mS	
Logic Levels						
Data Output Logic 1	All		3.1		Volts	10k load to 0V Gnd
Data Output Logic 0			0.1		Volts	10k load to internal +Vreg supply
Data Output Current		6		15	mA	Under software control Hi/Lo drive
Data Input Logic 1		2.0		3.6	Volts	
Data Input Logic 0		0		0.2	Volts	
Input Pull-ups/Downs			100		kΩ	Under software control To internal +Vreg or 0V Gnd
RF Parameters						
Antenna Impedance	24		50		Ohms	Via UFL connector or pads
Operating Frequency		389	434.00	470	MHz	See Configuration Command set
		779	869.75	902	MHz	
		902	915.00	928	MHz	
Modulation	FSK Wideband MSK at 500kbps					
Transmitter						
RF Power Output 434MHz	24	-30	Set by user	+12	dBm	50Ω load – 434MHz
RF Power Output 869MHz	24	-30	Set by user	+7	dBm	50Ω load – 869MHz
RF Power Output 915MHz	24	-30	Set by user	-3	dBm	50Ω load – 915MHz
Frequency Accuracy			±10	±15	ppm	Overall
FSK Deviation (Min)			±5.2		kHz	1.2kbps 58kHz filter bandwidth
FSK Deviation (Max)			±127		kHz	250kbps, 540kHz Filter bandwidth
Harmonics & Spurious Emissions	24		-47	< -36	dBm	Meets EN 300 220-3
Over-Air Data Rate		1.2	38.4	500	Kbps	Configurable
Receiver						
Receive Sensitivity 433MHz	24		-111		dBm	At 1.2kbps Over-Air data rate
868/915MHz	24		-109		dBm	At 1.2kbps Over-Air data rate
434MHz	24		-91		dBm	At 500kbps Over-Air data rate
868/915MHz	24		-81		dBm	At 500kbps Over-Air data rate
Host Serial Data Rate	3, 4	1.2	19.2	115.2	Kbps	Host interface
Mechanical						
Size	15 x 20 x 2.2				mm	
Pin/Pad Pitch	2.54				mm	Standard 0.1 Inch
Weight	1.5				grams	

*All Specifications are subject to change without notice

Notes

When power is first applied to the module the processor retrieves 'calibration' data for the RF section that compensates for temperature and power supply voltage variations. The transceiver will then be ready to transmit or receive (default) and would normally be left in this state, ready to receive data.

The internal Vreg is not brought out to a specific pin/pad. Should there be need to connect external pull up resistors then connection should be made to a spare GPIO pin/pad configured as a 'High' output.

Power Supply

The supply used to power the transceiver should be 'clean' and free from ripple and noise (<20mV p-p total). It is suggested that 100nF ceramic capacitors be used to de-couple the supply close to the power pins of the transceiver. The use of 'switch mode' power supplies should generally be avoided as they can generate both conducted and radiated high frequency noise that can be very difficult to eliminate. This noise may considerably reduce the performance of any radio device that is connected or adjacent to such a supply.

Antennas

The eRIC transceiver can be used with the various common types of antenna that match the 50Ω RF Input/Output such as a monopole (whip), a tuned helical antenna, a PCB loop antenna or a ceramic 'chip' antenna.

Monopole antennas are resonant with a length corresponding to one quarter of the electrical wavelength ($\lambda/4$). They are very easy to implement and can simply be a 'piece of wire' or PCB track which at 434MHz should be 16.4cms in length. This should be kept straight, in 'free space' and well away from all other circuitry, conducting objects and metalwork and should preferably be connected directly to the Antenna pin (24) of the eRIC transceiver.

If the antenna needs to be remote it should be connected via a 50Ω coaxial feeder cable or transmission line. A 50Ω transmission line can be constructed on FR4 board material by using a 3mm wide PCB track over a ground plane and this should be kept as short as possible.

The eRIC transceiver is also fitted with UFL (U.FL) RF Connector wired in parallel with pin 23 (RF Gnd) and pin 24 (RF In/Out). LPRS can supply suitable antennas fitted with matching connectors and low loss cable assemblies.

Helical antennas are also resonant and generally chosen for their more compact dimensions. They are more difficult to optimise than monopole antennas and are critical with regard to any surrounding conducting objects that can easily 'de-tune' them. They operate most efficiently when there is a substantial ground plane for them to radiate against.

PCB loop antennas are the most compact antennas but are less effective than the other types. They are also more difficult to design and must be carefully 'tuned' for best performance.

Chip antennas are attractive as they are compact and if used in accordance with the manufacturer's specifications can provide very good performance.

The Internet can provide much useful information on the design of Short Range Device (SRD) Antennas.

Please Note: To meet US FCC requirements the modules must be used with the specified antennas that were used for testing.

eRIC4 Antenna Options	eRIC9 Certified FCC Antennas
ANT-SS433	ANT-900MS MR
ANT-SR433	ANTWP915 SMA-Y
ANT-433MS	ANT-SS900
ANT-433MR	ANT-SR900
ANT-WP433 SMA-Y	ANT-RP915 SMA-Y

ESD

The module has passed Electro Static Discharge tests under RED certification with no additional external circuitry.

Metallic antennas should preferably be insulated with a plastic covering to prevent accidental direct electrical connection and to reduce the ESD potential. Antenna and RF Ground connections should always be kept as short as possible.

4 Mechanical

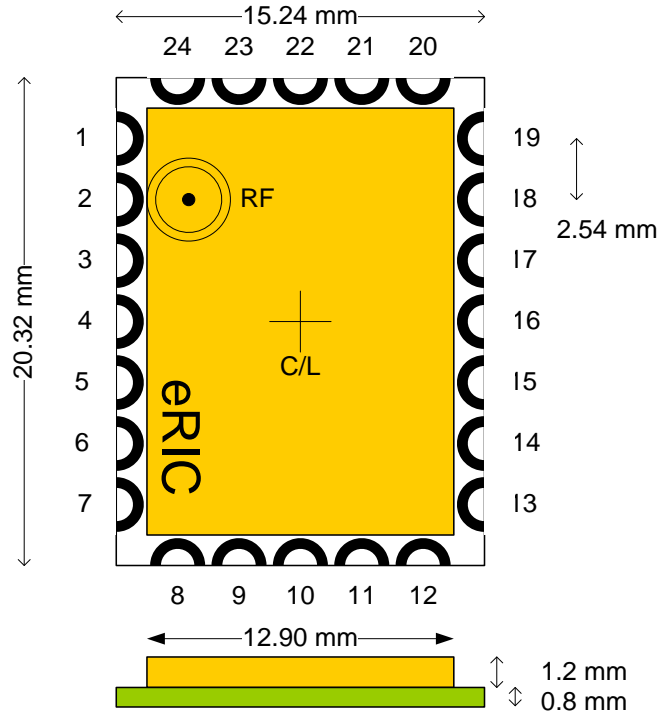

Figure 2 Mechanical Drawing

4.1 PCB Layout Notes

Pitch of the castellated connection pads is 2.54mm. Pads 4 & 16 and 10 & 22 are on centre line (C/L) of module

It is recommended that the module is mounted on a double sided PCB and that the area below the module be flooded with additional copper ground plane. This should be connected to pad 23 (RF Ground) and pad 7 (Power Ground).

The recommended pad layout is shown below. Pads should be solid with no hole.

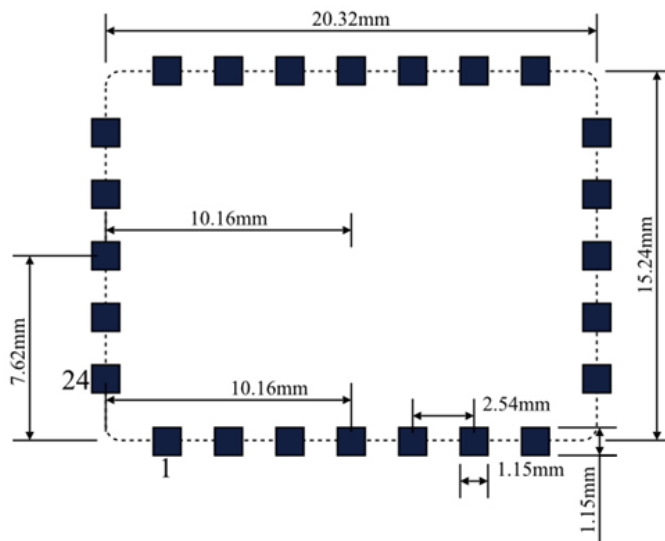

Figure 3 Pad Layout

4.2 Production - soldering & reflow

eRIC modules have been designed for reflow soldering but should only be subjected to this process once. Multiple passes may cause permanent internal component damage and is therefore not recommended. Should multiple reflows take place, the customer does so at their own risk and LPRS provides no warranty against damages caused to this module.

For optimum reflow of this module, please see below our recommended reflow soldering profile for this device.

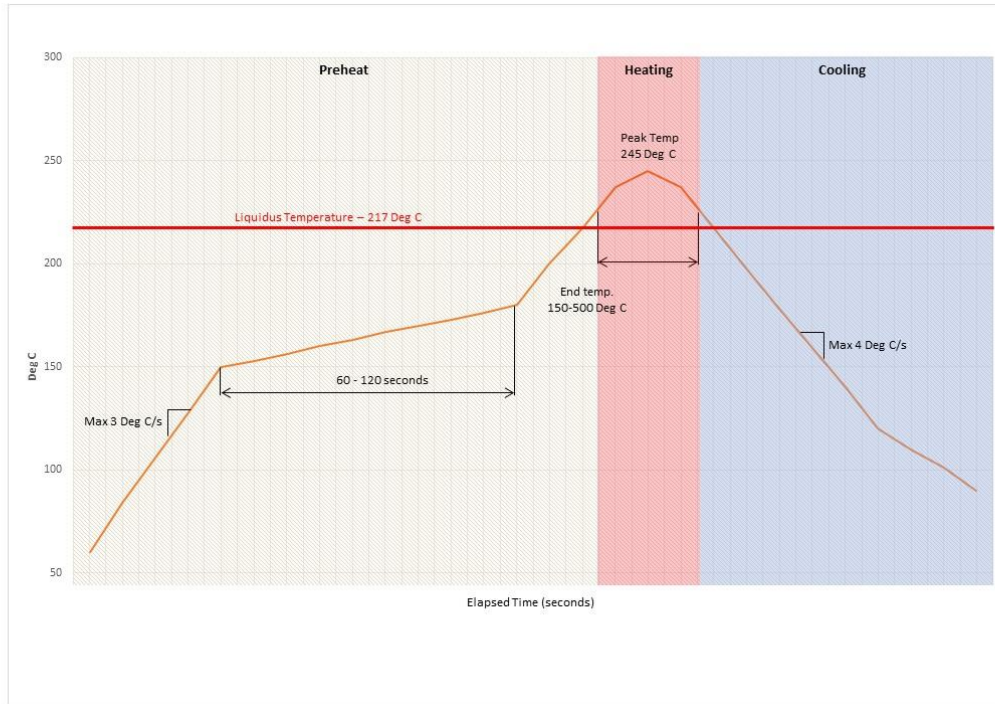

Figure 4 Soldering profile

Please note that whilst every care and attention has been made by LPRS to ensure this profile is correct, each manufacturing process is subtly different and we recommend consulting with your manufacturing facility prior to production to ensure this profile is suitable for use with your overall PCB assembly process.

4.3 Soldering Paste & Stencil Thickness

LPRS recommend a solder past thickness of between 100 to 150 microns. Of course, each customer's specific implementation of the eRIC component is different and thus, the selected soldering paste thickness depends on the specific manufacturing requirements of the host printed circuit board and components used.

Please note that our statements relating to manufacturing procedures are recommendations only and not specifications. The exact solder, copper, paste mask dimensions, stencil thicknesses and solder paste quantity must be adapted to the specific production process of the customers designed PCB.

4.4 Conformal coating.

Conformally coating LPRS's RF products may adversely affect the operation and RF performance of the device and therefore we would not recommend this course of action. If your application requires a coating of some kind, customers should conduct their own tests to ensure suitability. Whilst the RF shielding CAN will provide some protection, all care and attention should be taken to ensure the coating does not flow into the module.

Please note that conformal coating of the module with any substance will invalidate the warranty.

If your application must have a conformal coating, please contact LPRS to discuss further.

5. Interface to Microcontroller

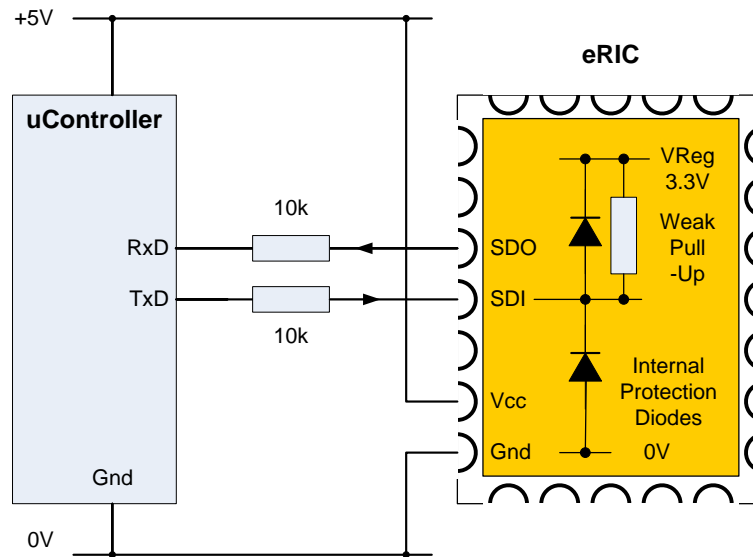

Figure 5 Connection to Host UART and I/O Protection

The transceiver module is powered internally by an on board 3.3V low drop voltage regulator. Any eRIC pin/pad configured as an input should not be connected directly to a voltage greater than 3.3V or less than -0.3V otherwise damage may occur to the module due to excess current flowing through the IC internal protection diodes. To prevent such damage this current should be limited by the use of a suitable (10k typical) series resistor (as shown above).

eRIC output pins can only provide a maximum high voltage of 3.3V (Vreg) and whilst not strictly necessary to use a series resistor in series with outputs it may afford protection under some fault conditions.

The serial data input (or any other pin) must NOT be directly connected to any RS232 level ($\pm 15V$) devices.

Serial data is inverted i.e. Start Bit is logic low. This allows direct connection to a microcontroller UART (Inverted data) or to RS232 devices via a voltage level translator device such as a Maxim MAX232, which invert the logic of the RS232 signals. Data is sent and received in standard serial 'RS232' format (logic level only) and there is no restriction on the characters (Hex 00 – FF) that may be sent or received.

The host should provide serial data input and output lines. The optional 'handshaking' lines can be used to control the flow of data between the host and eRIC. If handshaking is not being used, then Pin5 (Host Ready) should either be left floating (internal pull down) or held low. The 'Host Ready Input' Pin5 should be tied to 0 Volt (Ground) if not used, only when handshaking is enabled.

The 'Busy' output line, when active, indicates that the transceiver is undertaking an internal task and is not ready to receive serial data. The 'Host Ready' input is used to indicate that the host is ready to receive the data held in the buffer of the easyRadio Transceiver. The host should check before sending data that the 'Busy' line is not high, as this would indicate that the transceiver is unable to reliably receive further data. It should also pull the 'Host Ready' line to receive data.

The 'Busy' output is active all the time regardless of handshaking setting. The 'Host Ready' is enabled by the handshaking setting.

6. Serial Data Timing

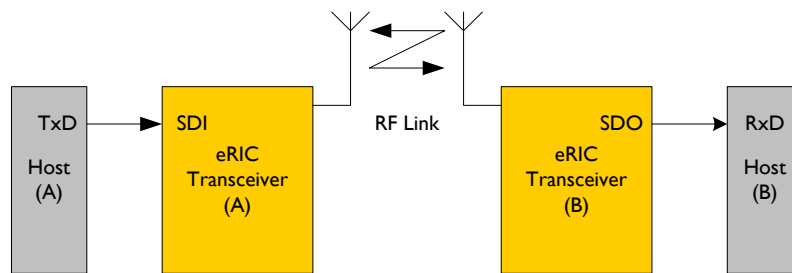

Figure 6 System Block Diagram

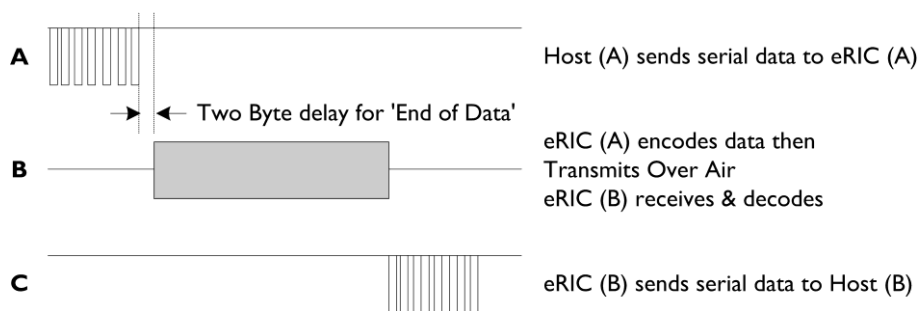

Figure 7 Timing Diagram

Parameter	Values	Notes
Host Serial Data Rate	1200, 2400, 4800, 9600, 19200, 38400 & 115200 Baud	Configurable – Default = 19200 Baud
Host Character Format	1 Start bit, 8 Data bits, No Parity, 1 Stop bit	10 bits @ 104uS/bit = 0.52mS/character at 19200 Baud
'End of Data' Delay	2 x Baud Byte duration	Twice character time
RF Transmit Duration	Depends on Over-Air RF data rate Default - 38400 bps	See drawing. Between 2 & 4 bytes of Preamble and other internal data are automatically added to every packet
Buffer Size	1-250 bytes maximum	

Notes

The serial data internal buffer size is limited to a maximum of 250 bytes. Data will be lost if more than 250 bytes are sent in any one transmission. RF transmission begins automatically when the buffer is full or when 'End of Data' (no data for twice the character time) is detected.

- A. Host (A) sends serial data to eRIC (A). The data must be continuously streamed (no breaks) at the selected host Baud rate and is loaded into an internal transmit buffer.
- B. After detecting either the 'End of Data' gap or the 'Buffer Full' condition the controller enables the RF transmitter circuitry of the transceiver and sends the data within the buffer together with preamble and other internal data across the RF link. Any eRIC transceiver operating in receive mode and within range that 'hears' the transmission will receive and decode the data, check for data integrity and place it into their receive buffers.
- C. Data within the receive buffer of eRIC (B) will be sent to Host (B) at the selected Baud rate.

Host (A) must allow time for the complete 'Over-Air' transmission and for the receiving Host (B) to unload (and process) the data before sending new data. (See Figure 5). There is no automatic 'RF handshaking' provided by the eRIC transceivers. Radio transmission and reception is bi-directional (half duplex) i.e. transmit OR receive (but not simultaneously) and there is no automatic confirmation of the satisfactory reception of the data.

The user application should therefore, either send the data repetitively to provide some redundancy or devise a scheme of acknowledgements (ACKs) and re-tries to increase the security and reliability of the transmitted data should need be.

7. easyRadio eRIC Configuration Command Set

Key operating parameters of eRIC can be changed and configured by sending the 'text' (ASCII character) commands detailed below. These commands can be executed using 'easyRadio Companion' software, any 'Terminal' software operating on a PC or from the host microcontroller.

The commands should be sent exactly as shown, i.e. case sensitive with no spaces between characters. Commands are not executed until the Acknowledgement (ACK) sequence is sent to and processed by the module.

To send the commands follow this procedure:

1. Send the Command from host: e.g. ER_CMD#U5 (Set UART BAUD to 38400)
2. Wait for the completion of the echo of the Command from the module. e.g. ER_CMD#U5
3. Send the ACK command as the three upper case ASCII characters 'A' 'C' 'K' in sequence with no spaces
4. A two byte delay is necessary after sending each command. For example, to change command at default 19200 (U4), 1.041ms delay (20 bits) is needed after command.
5. Received Over-Air data is not delivered for a timeout delay of 200ms if a command is sent and is not completed. A timeout delay of two bytes (20 bits) is added before delivering Over-Air received data if command is completed.

Host Serial Communication Settings							
Command	UART Data Rate		Tick indicates Factory Default setting N.B. Clock speed should be $\geq 9 \times$ UART Baud rate				Note
ER_CMD#U0	1200		Clock speed should be ≥ 10800 or 20kHz				
ER_CMD#U1	2400		Clock speed should be ≥ 21600 or 32kHz				
ER_CMD#U2	4800		Clock speed should be ≥ 43200 or 50kHz				
ER_CMD#U3	9600		Clock speed should be ≥ 86400 or 90kHz				
ER_CMD#U4	19200	✓	Clock speed should be ≥ 172800 or 180kHz				
ER_CMD#U5	38400		Clock speed should be ≥ 345600 or 350kHz				
ER_CMD#U8	115200		Clock speed should be ≥ 1036800 or 1.1MHz				
ER_CMD#U?	Get UART Value		Returns the current UART value. E.g. ER_CMD#U2 - No 'ACK' required				
Transmit RF Power Settings							
			eRIC4 433MHz	eRIC9 869.75 – 870MHz	eRIC9 902 – 928 MHz	eRIC9 Other frequencies	Units
ER_CMD#P0	Minimum Power		0	-2	-12	0	dBm
ER_CMD#P1			1	-1	-11	1	dBm
ER_CMD#P2			2	0	-10	2	dBm
ER_CMD#P3			3	1	-9	3	dBm
ER_CMD#P4			4	2	-8	4	dBm
ER_CMD#P5			5	3	-7	5	dBm
ER_CMD#P6			6	4	-6	6	dBm
ER_CMD#P7			7	5	-5	7	dBm
ER_CMD#P8			8	6	-4	8	dBm
ER_CMD#P9	Maximum Power	✓	9	7	-3	9	dBm
			To increase Power Output to +12 dBm send the following commands: ER_CMD#P9 followed by ACK ER_CMD#L4ID0C followed by ACK				
ER_CMD#P?	Get RF Power output value		Returns the current RF power output value E.g. ER_CMD#P9 - No ACK required				
RF Channel Settings							
ER_CMD#Cx	Where x = Channel Number in Decimal. Only channels (0-9) implemented at present.		E.g. For Channel 5 – 434.500MHz For Channel 5 – 870.250MHz For Channel 5 – 915.500MHz		eRIC4 eRIC9 eRIC9 (Pin 14 Low)		
ER_CMD#C0		✓	Sets base frequency to: 434.000MHz, 869.75MHz, 915.000MHz				
ER_CMD#C1-8			Set intermediate frequency values at 100kHz steps				
ER_CMD#C9			Sets frequency to 434.900MHz (434.000 + 900KHz)				
ER_CMD#C?	Get Channel Value		Returns the current channel. E.g. ER_CMD#C0 - No ACK required				
RF Frequency Settings							
ER_CMD#F xxxxxxx	Set Absolute Frequency		Sets the absolute frequency to xxxxxxxx in Hex E.g. ER_CMD#F1B4C8680 sets the radio frequency to 458000000Hz ACK required				
ER_CMD#F?	Get current Frequency value		Returns the current frequency value as 8 bytes of Hex. E.g. ER_CMD#F? Returns 1B4C8680 which is 458.00MHz. ACK required				

CPU Frequency Settings			
ER_CMD# xxxxxxx	Set Absolute CPU Frequency	<p>Sets the absolute CPU frequency to xxxxxxxx in Hex E.g. ER_CMD#f0044AA20 sets the CPU frequency to 4500000Hz. Frequencies can be 10kHz, 20kHz, 32768Hz, 40kHz, 50kHz, 60kHz and anything from 70kHz-20MHz.</p> <p>CPU Clock speed should be $\geq 9 \times$ UART Baud rate. For example at 19200 Baud rate, Clock speed should be ≥ 172800 or 180kHz</p> <p>CPU Clock speed should also be $\geq 9 \times$ Over-Air Baud rate. For example at 38400 Baud rate, Clock speed should be ≥ 345600 or 350kHz</p> <p>For Clock speeds that do not meet $9 \times$ Over-Air Baud rate requirement the packet size is limited to only 60 bytes when transmitted. And also d1-7 levels are treated as d0 ACK required</p>	VI.5
ER_CMD#?	Get current CPU Frequency value	Returns the current frequency value as 8 bytes of Hex E.g. ER_CMD#? Returns 0044AA20 which is 4.5MHz ACK required	VI.5
Over-Air Data Rate			
ER_CMD#B0	1200 bps.	CPU Clock speed should also be $\geq 9 \times$ Over-Air Baud rate Clock speed should be ≥ 10800 or 20kHz	
ER_CMD#B1	2400 bps	Clock speed should be ≥ 21600 or 32kHz	
ER_CMD#B2	4800 bps	Clock speed should be ≥ 43200 or 50kHz	
ER_CMD#B3	9600 bps	Clock speed should be ≥ 86400 or 90kHz	
ER_CMD#B4	19200 bps	Clock speed should be ≥ 172800 or 180kHz	
ER_CMD#B5	38400 bps	✓ Clock speed should be ≥ 345600 or 350kHz (Default).	
ER_CMD#B6	76800 bps	Clock speed should be ≥ 691200 or 700kHz	
ER_CMD#B7	100000 bps	Clock speed should be ≥ 900000 or 900kHz	
ER_CMD#B8	250000 bps	Clock speed should be ≥ 2250000 or 2.25MHz	
ER_CMD#B9	500000 bps	Clock speed should be ≥ 4500000 or 4.5MHz	
ER_CMD#B?	Get the Over-Air Data Rate value	Returns the current Over-Air data rate value as command setting value E.g. ER_CMD#B5 - not the integer bps value No ACK required	
Radio Receive - Power Saving			
	On Time	Typical Average Receive Current	
ER_CMD#D0	100%	✓ 16mA	No Power Saving (Default)
ER_CMD#D1	12.50%	2mA	N.B. eRIC_EEPROM Write is disabled. So any commands after this command will not be stored in EEPROM. Any radio parameter or command which needs to be restored on power up should be set in D0 or D8 settings. (VI.5.5)
ER_CMD#D2	6.25%	1mA	
ER_CMD#D3	3.33%	500uA	
ER_CMD#D4	1.56%	250uA	
ER_CMD#D5	0.78%	125uA	
ER_CMD#D6	0.39%	63uA	
ER_CMD#D7	0.20%	32uA	
ER_CMD#D8	0%	0uA	
ER_CMD#D?	Gets the current Rx Power Saving level		Returns current Receive Power Saving Level. No ACK required
Radio Transmit - Power Saving			
ER_CMD#d0		✓	<p>This setting must be used in conjunction with the Radio Receive Power saving setting: ER_CMD#dx \geq ER_CMD#Dx</p> <p>N.B. If the Radio Receive is set by command ER_CMD#D4, the communication would fail if transmitter is set with command less than ER_CMD#d4.</p> <p>It will only work if the transmitter is set with command ER_CMD#d4, d5, d6 etc. or above CPU Clock speed should also be $\geq 9 \times$ current Over-Air Baud rate.</p>
ER_CMD#d8			Radio goes into Idle and Sleep mode only when Radio Power Saving is on D8
ER_CMD#d?	Gets the current Tx Power Saving level		Return current Radio Transmit Power Saving Level. No ACK required

Group ID Settings			
ER_CMD#L7 xxxx	Enable Group ID (2 bytes)	E.g. ER_CMD#L74578 sets the group ID as 0x4578.	VI.1
ER_CMD#L7 0000	Disable Group ID		VI.1
ER_CMD#L7?	Get Group ID value	Returns the 4 byte Group ID number in Hex.	VI.1
EEPROM Settings			
ER_CMD#L8?	Get the Serial Number of the module	Returns the unique 4 byte module Serial Number in Hex E.g. 40000056 No ACK required	VI.1
ER_CMD#L4 xxxx	Writes data to EEPROM at location xx	E.g. ER_CMD#L4FE2A - Write the data 0x2A at EEPROM address 0xFE Where xxxx is the address followed by the data in hexadecimal eRIC_Eeprom_Write is disabled in D1-7. So this command doesn't work in D1-7 modes.	VI.1
ER_CMD#L4 xx?	Returns the data located at EEPROM address xx	E.g. ER_CMD#L4FE? Returns data as 0x2A Where xx is the EEPROM address in hexadecimal from 0-FF EEPROM is only 256Bytes and ranges from 0x00-0xFF	VI.1
Miscellaneous Settings			
ER_CMD#R0	Reset Radio and performs brown out reset (BOR)	Module restarts by resetting all the radio settings and retrieve all the (Default) radio settings P9, C0, D0, d0, U5, B5, L70000, A10, A20, Z00,4.5MHz CPU clock,434/869.75/915MHz Radio frequency.	
ER_CMD#R1	Brown Out Reset (BOR)	Software Brown Out Reset (BOR) and restart the radio with previously stored settings	VI.5
ER_CMD#R2	Bootloader Mode	Enables bootloader mode and firmware can be upgraded using UART on Pin3 and Pin4. This mode can only be exited by the successful upgrade of firmware.	VI.5
ER_CMD#R?	Cause of last Reset	Return the value for the cause of last reset. If low bytes is: 00h = No cause 02h = Brownout (BOR) 04h = RST/NMI (BOR) 06h = PMMSWBOR (BOR) 08h = Wakeup from LPM (BOR) 0Ah = Security violation (BOR) 0Ch = SVSL (POR) 0Eh = SVSH (POR) 10h = SVML_OVP (POR) 12h = SVMH_OVP (POR) 14h = PMMSWPOR (POR) 16h = WDT time out (PUC) 18h = WDT password violation (PUC) 1Ah = Flash password violation (PUC) 1Ch = Reserved 1Eh = PERF peripheral/configuration area fetch (PUC) 20h = PMM password violation (PUC) 22h to 3Eh = Reserved ACK required	VI.5.5
Test Modes			
ER_CMD#T0	Upper FSK	Transmit continuous upper FSK Carrier	
ER_CMD#T1		Transmit continuous modulated Carrier at selected Over-Air data rate.	
ER_CMD#TIU		Transmit continuous Un-calibrated modulated Carrier at selected Over- Air data rate.	VI.4
ER_CMD#T2	Lower FSK	Transmit continuous lower FSK Carrier	
ER_CMD#T3	Get Firmware Revision	Returns firmware revision string in ASCII e.g. eRIC400xxxx	
ER_CMD#T4	RAW Data mode	Output the demodulated received data on Pin 2	
ER_CMD#T5	Packet Mode	✓ Set the radio into normal packet data mode	VI.1
ER_CMD#T6	Carrier Off	End any continuous transmit modes	
ER_CMD#T7	Get Temperature	Returns internal chip temperature in decimal Degrees C. e.g. 20.5°C	
ER_CMD#T8	Last Packet RSSI	Returns the Received Signal Strength Indication (RSSI) of the last packet in dBm with sign (only in Packet Mode) e.g. -74dBm	VI.1
ER_CMD#T9	Get live RSSI	Returns the live RSSI value in dBm with sign e.g. -102dBm	

AES Encryption Settings			
ER_CMD#A1xy yyyyyyyyyyyyyy yyyyyyyyyyyyyy y	Set AES command	✓ Where; x = 0 AES disabled (Default) x = 1 AES enabled with both encryption and decryption x = 2 AES encryption only enabled x = 3 AES decryption only enabled y = 32 character encryption key For example to set AES as encryption with key (0123456789ABCDEF0123456789ABCDEF) the command should be: ER_CMD#A10123456789ABCDEF0123456789ABCDEF (AES is enabled with both encryption and decryption) ER_CMD#A120123456789ABCDEF0123456789ABCDEF (AES is enabled with only encryption) ER_CMD#A130123456789ABCDEF0123456789ABCDEF (AES is enabled with only decryption) ER_CMD#A10. (AES encryption and decryption Off)	V1.5
ER_CMD#A1?	Returns the current AES settings	Returns with ER_CMD#A1x where x = 0, 1, 2, or 3 Default = Off ACK required	V1.5
CarrierDetect Settings			
ER_CMD#A1px x	Where p = Polarity, xx is RSSI value in hex	Pin1 is assigned as CarrierDetect. P = 0 Rest at 0, Pin1 is high when carrier is detected. P = 1 Idle high, Pin1 is low when carrier is detected. xx is RSSI value in hex, CarrierDetect is set/cleared when live RSSI is above or below this RSSI value based on polarity When xx = 0xFF, Carrier Detect is disabled (Default)	V1.5.5
ER_CMD#A1?	Returns current carrier detect settings	Return Polarity and RSSI value. IF RSSI is 0xFF, Carrier Detect is disabled (Default) ACK required	V1.5.5
Low Power Mode Settings			
ER_CMD#A21		eRIC_LPM_Level0() is enabled. Clock is set to 1048576Hz and D7 (RxPower level) is enabled. UART Baud rate (U4)19200 is also selected. . Pin22 is used to enter/exit this mode. Pull down enabled on Pin22. It enters Lowpowermode when Pin22 is pulled low and exits when it pulled Low-High. It is not recommended to change commands or any radio setting when Pin22 is low and after this command is sent. All other interrupts are disabled except UART, Pin22 and Radio. eRIC can send data and receive data. On exiting this mode, Clock, RxPowerSavinglevel, UART is changed back to whatever it was set to before. Current consumption ~104-180 uA	V1.5.5
ER_CMD#A22		eRIC_LPM_Level1() is enabled. Clock is set to 32768Hz and D7 (RxPower level) is enabled. UART Baud rate (U0)1200 is also selected. Pin22 is used to enter/exit this mode. Pull down enabled on Pin22. It enters Lowpowermode when Pin22 is pulled low and exits when it pulled Low-High. It is not recommended to change commands or any radio setting when Pin22 is low and after this command is sent. All other interrupts are disabled except UART, Pin22 and Radio. eRIC can send data and receive data. When it exits this mode, Clock, RxPowerSavinglevel, UART is changed back to whatever it was set before. Current consumption ~37uA. If ER_CMD#D8 (Radio receiver Off) (Can send data but not receive data) Current consumption ~6uA	V1.5.5
ER_CMD#A23		eRIC_LPM_Level2() is enabled. All clocks are turned off. Radio is off. Pin22 is used to enter/exit this mode. Pull down enabled on Pin22. It enters Lowpowermode when Pin22 is pulled low and exits when it pulled Low-High. It is not recommended to change commands or any radio setting when Pin22 is low and after this command is sent. When it exits this mode, radio resumes its functions as set before. Current consumption ~2uA	V1.5.5

ER_CMD#A2?	Returns the current low power mode		ACK required Default = 0	VI.5.5
ER_CMD#A81	Same as ER_CMD#A21 but Clock, RxPowerSaving level and UART are not changed		eRIC_LPM_Level0() is enabled. Pin22 is used to enter/exit this mode. Pull down enabled on Pin22. It enters Lowpowermode when Pin22 is pulled low and exits when it pulled Low-High. It is not recommended to change commands or any radio setting when Pin22 is low and after this command is sent. All other interrupts are disabled except UART, Pin22 and Radio. eRIC can send data, receive data and update settings.	VI.5.5
ER_CMD#A82	Same as ER_CMD#A22 but Clock, RxPowerSaving level and UART are not changed		eRIC_LPM_Level1() is enabled. Pin22 is used to enter/exit this mode. Pull down enabled on Pin22. It enters lowpowermode when Pin22 is pulled low and exits when it pulled Low-High. It is not recommended to change commands or any radio setting when Pin22 is low and after this command is sent. All other interrupts are disabled except UART, Pin22 and Radio. eRIC can send data and receive data.	VI.5.5
ER_CMD#A83	Same as ER_CMD#A23		eRIC_LPM_Level2() is enabled. All clocks are turned off. Radio is off. Pin22 is used to enter/exit this mode. Pull down enabled on Pin22. It enters Lowpowermode when Pin22 is pulled low and exits when it pulled Low-High. It is not recommended to change commands or any radio setting when Pin22 is low and after this command is sent. Current consumption ~2uA	VI.5.5
ER_CMD#A8?	Returns the current low power mode		ACK required Default = 0	VI.5.5
Handshake Settings				
ER_CMD#A50	Handshaking Off	✓	(Default)	VI.5
ER_CMD#A51	Handshaking On		(Pin2 CTS, Pin5 RTS) See notes	VI.5
ER_CMD#A5?	Returns current Handshake setting		ACK required	VI.5
Carrier Mode Settings				
ER_CMD#Z01	High side Carrier Mode On		On start up or Reset Used mainly for FCC testing purposes	VI.5
ER_CMD#Z02	Modulated Carrier Mode On		On start up or reset Used mainly for FCC testing purposes	VI.5
ER_CMD#Z03	Low side Carrier Mode On		On start up or reset Used mainly for FCC testing purposes	VI.5
ER_CMD#Z00	No Carrier Mode	✓	On start up or Reset. (Default)	VI.5
ER_CMD#Z0?	Returns Carrier Mode		Returns with ER_CMD#Z00 or 1, 2, 3 ACK required	VI.5

Current Consumption					
	Min	Typical	Max	Units	Notes
With standard eRICxeasyRadioVI.5.5 and eROS V4.5		19.7		mA	VI.5.5 and eROS V4.5
ER_CMD#Z01, Z02, Z03 Continuous transmitter On +10 dbm (P9)		29.5		mA	
ER_CMD#D8, Receiver Off		1.1		mA	
ER_CMD#A21	104		180	uA	
ER_CMD#A22	6		40	uA	
ER_CMD#A23/ER_CMD#A83		2		uA	
ER_CMD#D8, ER_CMD#A21		104		uA	
ER_CMD#D8, ER_CMD#A22		5.8		uA	
ER_CMD#U0,ER_CMD#A82(Pin22 high) ER_CMD#0007A120(500kHz), ER_CMD#D8		80.6		uA	
ER_CMD#U0,ER_CMD#A82 (Pin22 high), ER_CMD#0007A120(500kHz), ER_CMD#D7	80		100	uA	
ER_CMD#01312D00 (20MHz clock)		22.9		mA	

Timings					
	Min	Typical	Max	Units	Notes
eROS Start-up from Reset		1.25		mS	VI.5.5 and eROS V4.5
eRIC Start-up from Reset		1.8		mS	
Time to receive first packet on start-up		70		mS	
Time to receive first packet on start-up at 1048576Hz clock (ER_CMD#00100000)		30		mS	
Time to send 1 byte of data from PC to Tx FIFO at default settings		3		mS	
Changing Channel or Power	220		260	mS	
Changing Radio frequency	300		380	mS	
Changing RF (Over-Air) Baud rate	260			mS	
EEprom Write	0.4		38	mS	
EEprom Read	0.3			mS	
Change Rx Power Saving settings	200		800	mS	

ER_CMD#Dx and ER_CMD#dx Settings & Timings explained:

The tables below indicate Receiver On+Off time and Transmitter Preamble time. The overall transmission or reception time depends upon the Clock speed, number of bytes in a packet, Over-Air Baud rate, UART Baud rate (if used) and other factors.

Receiver ON+OFF time in mS								
Bx\Dx	Baud	ER_CMD #D1	ER_CMD #D2	ER_CMD #D3	ER_CMD #D4	ER_CMD #D5	ER_CMD #D6	ER_CMD# D7
		12.5%	6.25%	3.13%	1.56%	0.78%	0.39%	0.2%
ER_CMD#B0	1200	169.90	339.70	678.40	1361.00	2722.00	5444.00	10620.00
ER_CMD#B1	2400	86.53	173.10	345.60	693.40	1387.00	2774.00	5408.00
ER_CMD#B2	4800	44.87	89.73	179.20	359.50	719.00	1438.00	2804.00
ER_CMD#B3	9600	24.03	48.07	95.98	192.60	385.10	770.30	1502.00
ER_CMD#B4	19200	13.62	27.23	54.38	109.10	218.20	436.40	851.00
ER_CMD#B5	38400	8.41	16.82	33.58	67.37	134.70	269.50	525.50
ER_CMD#B6	76800	5.80	11.61	23.18	46.51	93.02	186.00	362.80
ER_CMD#B7	1000000	5.20	10.40	20.77	41.67	83.33	166.70	325.00
ER_CMD#B8	250000	4.00	8.00	15.97	32.05	64.10	128.20	250.00
ER_CMD#B9	500000	3.60	7.20	14.38	28.85	57.69	115.40	225.00

Transmitter Preamble Time in mS								
CPU Clock speed should also be $\geq 9 \times$ current Over-Air Baud rate								
Bx\dx	Baud	ER_CMD #d1	ER_CMD #d2	ER_CMD #d3	ER_CMD #d4	ER_CMD #d5	ER_CMD# d6	ER_CMD# d7
		12.5%	6.25%	3.13%	1.56%	0.78%	0.39%	0.2%
ER_CMD#B0	1200	190.70	360.60	699.20	1382.00	2743.00	5465.00	10640.00
ER_CMD#B1	2400	96.95	183.50	356.00	703.80	1397.00	2784.00	5419.00
ER_CMD#B2	4800	50.08	94.94	184.40	364.70	724.20	1443.00	2809.00
ER_CMD#B3	9600	26.64	50.67	98.58	195.20	387.80	772.90	1505.00
ER_CMD#B4	19200	14.92	28.54	55.68	110.40	219.50	437.70	852.30
ER_CMD#B5	38400	9.06	17.47	34.23	68.03	135.40	270.10	526.20
ER_CMD#B6	76800	6.13	11.93	23.51	46.83	93.34	186.40	363.10
ER_CMD#B7	1000000	5.45	10.65	21.02	41.92	83.58	166.90	325.30
ER_CMD#B8	250000	4.10	8.10	16.07	32.15	64.20	128.30	250.10
ER_CMD#B9	500000	3.65	7.25	14.43	28.90	57.74	115.40	225.10

8. Transmission restrictions

As with all devices using the ISM license free radio spectrum, LPRS's eRIC4/9 must comply with regional restrictions on spectrum access and use. Restrictions are usually limited to 4 main topics:

- 1) Operational frequency band (What frequency you are using to transmit data on).
- 2) Maximum effective radiated power (How much output power you are using to transmit).
- 3) Channel access (aka Duty Cycle, how long you are transmitting for each time you transmit and how often you are transmitting).
- 4) Maximum occupied bandwidth (How much of the band you can transmit over).

8.1 eRIC transmission guide

eRIC4/9 is extremely flexible and capable of transmitting within whatever local restrictions you may have. As a guide please see below an indication of how often / how much eRIC4 or 9 can be used:

Region	Frequency	Output Power	Duty Cycle	Bandwidth
EU (CE/RED)	868.0MHz – 868.6MHz	25mW (+13dBm)	1%	Whole band
EU (CE/RED)	869.4MHz – 868.65MHz	500mW (+26.9Bm)	10%	Whole band
EU (CE/RED)	869.7MHz – 870.0MHz	5mW (+13dBm)	100%	Whole band
USA (FCC)				

Please note: Information provided for guidance only and applies to eRIC9, customers should conduct their own investigations into local regulations and restrictions.

Please contact LPRS to discuss the best operating profile for your device.

9. Product Order Codes

Name	Description	Frequency	Order Code
eRIC400	UK/European Transceiver Module (Can Marked '4')	433MHz	eRIC4
eRIC900	Europe/US Transceiver Module (Can Marked '9')	868/915MHz	eRIC9
eRIC Dev Kit	eRIC Development Kit including two eRIC400 modules	433MHz	eRIC4-DK
eRIC Dev Kit	eRIC Development Kit including two eRIC900 modules	868/915MHz	eRIC9-DK

9.1 Firmware

eRIC4 & 9 will be supplied with the latest release of firmware unless otherwise specified. Please contact LPRS to discuss being supplied with an eRIC4 & 9 with a previous or custom version of firmware.

9.2 Programming Modules in Situ

LPRS recommends customers make provision for programming the modules firmware physically through their host MCU or separate programming port.

9.3 MTBF

The mean time before failure is >100 Years.

10. Regulatory Approvals

eRIC4 & 9 are approved in accordance with CE/EU/RED and FCC regulatory approvals for devices using the Industrial, Scientific and Medical (ISM) license free radio spectrum.

LPRS approves our devices to these levels meaning customers benefit from reduced product testing by using our pre-approval certificates. For the latest up-to-date certificates please follow the below link to our website.:

<http://www.lprs.co.uk/knowledge-centre/regulatory-approvals.html>
See section 8.1 for Duty cycle restrictions.

11. Document History

Issue	Date	Notes/Comments
Preliminary 0.1 to 0.2	July 2013	Preliminary internal drafts
Preliminary 0.30 to 0.36	July/August 2013	Additions, amendments and minor corrections
VI.0	January 2014	First release
VI.1	June 2014	Additions and minor corrections
VI.2	May 2015	Additions, low power modes, EEprom data added
VI.3	February 2017	Power saving data tables and new commands added
VI.34	April 2018	Product picture updated. Renamed as current filename.
VI.4	March 2020	Added Solder Reflow Profile. Removed User App References

Changes to this Document

This data sheet has been updated to reflect changes throughout the range of LPRS modules. Specific changes are recorded in the documentation history above.

Copyright

See: www.lprs.co.uk

Disclaimer

See: www.lprs.co.uk

Terms and Conditions of Use

See: www.lprs.co.uk

Contact Information

For further information or technical assistance please contact: